

# Stainless steel conveyors

**CDA conveyors (available in aluminium or stainless steel) are motorised and facilitate the movement of products at a fixed speed on our filling, capping, and labelling machines.**

Mounted on a tripod with jacks, they are adjustable in height (+ or - 20 mm). Our conveyors are also equipped with adjustable side guides to accommodate different products, and feature a pallet chain (various materials are available, such as acetal, WPP, stainless steel, PFX, etc.). Many options are available (conveyor length and height, chain width and material, etc.) to perfectly tailor them to the diverse needs of businesses.

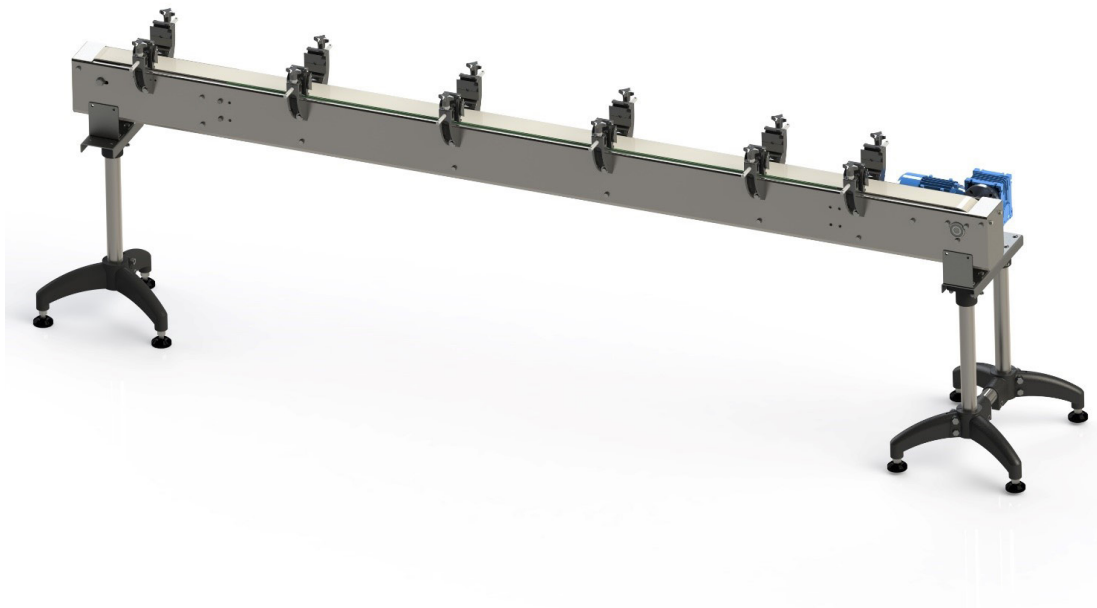

*Example of a standard 2 metre linear conveyor*

## The conveyors are equipped with :

- Adjustable height feet (with jack mechanism)
- Stainless steel side guides (diameter: 12mm)
- Pallet chain (standard material: acetal - standard width: 82.5 mm)
- Free side with traction head
- Standard height: 925 mm

## Characteristics of conveyors

- The different possible conveyor materials :
  - Steel
  - Stainless steel
- Various possible chain widths :
  - 82.6 mm
  - 114 mm
  - 190 mm
- Various chain materials available :
  - Acetal
  - WPP (polypropylene)
  - Stainless steel
  - PFX

## Available options

- Additional conveyor length
- Pneumatic cylinder lock
- $\varnothing$  700mm or  $\varnothing$  1000mm motorised infeed table (at machine entrance) including :
  - HDPE strapping
  - Variable frequency drive to modulate rotation speed
  - A guide (adjustable) to bring the products to the conveyor entrance
  - Stuffing cell
- $\varnothing$  700mm or  $\varnothing$  1000mm motorised receiving table (at machine exit) including :
  - HDPE strapping
  - A frequency inverter to modulate the speed of rotation
  - A guide (adjustable) to bring the products to the table
- Rectangular infeed / outfeed table:
  - Size 1600 \* 800mm
  - A tamping cell
  - 1m additional conveyor
- Jam cell at the infeed/outfeed of the labeller or filler conveyor belt
- A system of chain washing tanks
- A transfer belt

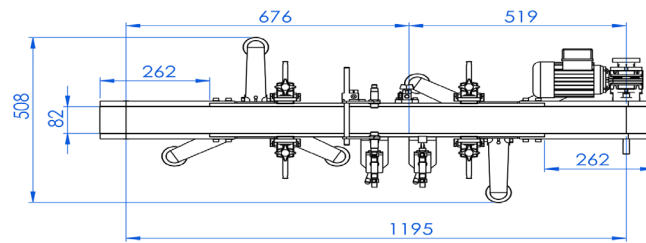
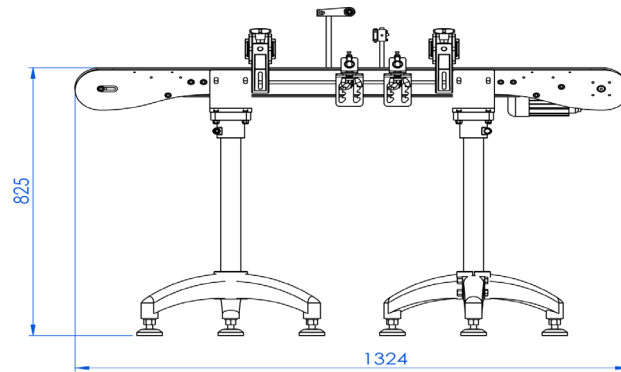

*Independent conveyor 1 lock*

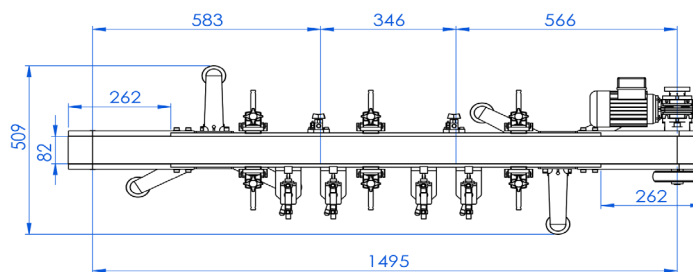
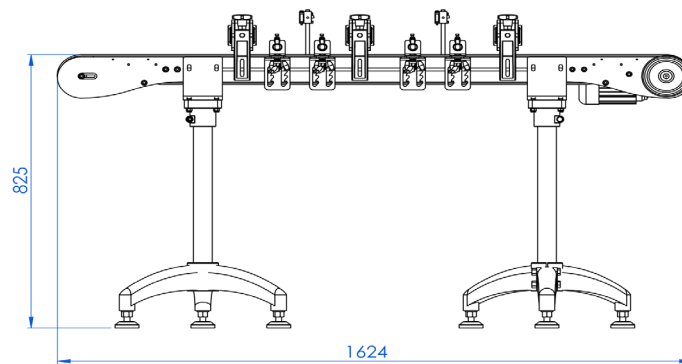

*Independent conveyor 2 locks*