

# Léa

**Automatic adhesive labeler and capper - Apply up to 4 labels (label, back label, medal, collar) to wine bottles.**

Suitable for wine bottles from 37.5 cl to 150 cl without additional tools.



## The Léa is an automatic labeler equipped with :

- All stainless steel chassis.
- Motorised conveyor (82.5mm wide).
- A multi-format automatic centring device.
- Multi-format selection screw.
- A labeling station adapted to cylindrical products. The height of the station can accommodate reel heights from 10mm to 155mm (standard). Label application height can be adjusted via the touch screen.
- A 40mm and 76mm mandrel (standard) on which to place the label roll. The label roll is designed to be wound on the outside left.
- A product detection cell to trigger label application.
- A pressure-sensitive cylinder for labeling products with diameters of between 40 and 90 115 mm (standard).
- A rotating cylindrical table at the machine output (for up to 60 bottles, depending on format).
- A touch screen to control and adjust the machine (up to 50 settings), plus a product counter.

## Available options

- A cap and/or cap dispenser (height adjustment via touch screen).
- A crimper for capsules (30mm diameter with a length of between 30 and 55 mm) or caps.
- A «Medals» station (height adjustment via touch screen).
- A station for fitting wraparound collars.
- Tilting of one or more application stations.
- A programme for labeling labels and back labels on the same roll.
- Raised application station(s). This option can accommodate reel heights of 285mm (versus 155mm as standard).
- A tapered kit to adapt labeling to certain tapered bottles.
- A marker/coder to apply a use-by date, barcode, etc.
- A register cell to align the label on a notch (for bottles with a coat of arms).
- An ultrasound cell for transparent labels.
- A label register cell.

*This machine is upgradeable: the options from above can be added on site with the intervention of a technician.*

## Limits of the Lea

- Bottles with a diameter greater than 115 mm and a height of 390 mm

## Technical characteristics Lea

APPROXIMATE MASS (LBS)	300 kg (depending option)
DIMENSIONS (WITH FRAME AND DEPENDING OPTION)	3301 mm in width 2106 mm in height 1565 mm of depth
POWER CONSUMPTION	1kW (depending option)
SUPPLY VOLTAGE	380 V 5 wires (3P + T + N) Or 380 V 4 wires (3P+T) + outlet 220 v (To be specified on your order)
FREQUENCY	6 bars Dry, non-lubricated air (Pipe Ø Int = 8 mm required)
CONTROL	by touch screen
IDEAL OPERATING TEMPERATURE	from 50°F to 90°F (10°C to 30°C)

**Please note that this machine requires an electrical and pneumatic power supply.**

## Technical focus n°1

### ROLLING DIRECTION : OUTSIDE LEFT

The machine is designed for label rolls with a left-hand outer winding direction. In addition, the dimensions of the rolls must be as follows:

- a : chuck diameter = 76 mm
- b : max. coil diameter = 260 mm
- c : max. labeling height = 155 mm (285 mm optional)
- d : label gap = 3-5 mm

The characteristics (material, weight, adhesive, dimensions, etc.) of the label must be consistent with the need and the type of bottle.

Important : Label reels should be stored in a dry place between 15°C and 18°C

*Don't hesitate to contact your sales representative or your printer. We can find solutions on a case-by-case basis.*

## Technical focus n°2

### MULTI-FORMAT AUTOMATIC CENTRING MACHINE

The automatic centring device is used to centre products positioned on the conveyor. The product can then undergo a given operation (dressing by a cap dispenser, a crimping station, etc.). The centring device is integral with the conveyor and adapts perfectly to the different formats of wine bottles (no adjustments or tooling changes required).

## Technical focus n°3

### TOUCHSCREEN

The colour touch screen allows easy adjustment of several parameters such as:

- Selection of stations and options
- Setting of time delays
- The speed of the clocking
- Daily product counter

## Technical focus n°4

### MULTI-FORMAT SELECTION SCREW

The selection screw is used to create a regular pitch between the products to be dressed. We say that it «cadences» the products (saving considerable time).

## Technical focus n°5

### CAPSULES DISPENSER (optional)

The capsule dispenser is a system for automatically depositing loose capsules on bottlenecks from capsule sticks. The height of the dispenser can be adjusted via the touchscreen.

The tray dimensions are 500 x 430 mm (maximum capacity 800 capsules - up to 1600 optional). This dispenser handles capsules with a diameter of 30 mm and a length of between 30 and 60 mm.

The capsules are ejected by a double blowgun, while a pneumatic cylinder deposits the capsule on the neck. The neck is centred and held automatically by the multi-format centring device.

## Technical focus n°6

### *CRIMPING SYSTEM (optional)*

Whether you choose a roller crimper (8 rollers - 1400 rpm) or a thermal crimper, this option is used to automatically crimp caps that have previously been placed on bottles.

The choice between one or another of these crimping machines depends on the composition of your capsules: metal or plastic. CDA's crimping systems are equipped with automatic bottle centring and holding devices. The pace and height of crimping can be adjusted via the touchscreen.

## Technical focus n°7

### *POSITION INCLINATION FOR CONICAL BOTTLES (optional)*

Tilting the station maximises labeling quality when the bottles to be labeled are slightly tapered (low to medium taper). The angle of tilt of the station is adjusted using a thumbwheel, and locked once the correct position has been set.

## Technical focus n°8

### *3rd POST / COLLERETTE POST (optional)*

The collar station is used to apply medals or collar labels. It has additional equipment compared with a «conventional» station: a vice and a tilting table (3 axes) to adjust the orientation of the station and a smoothing system (pneumatic cylinder).

## Technical focus n°9

### *ELECTRIC SHIFT ADJUSTMENT*

The CDA labeling station is mounted on an electric column, enabling the height of the label to be adjusted via the touch screen. No manual adjustments or tools are required to set the label height.

## Technical focus n°10

### *ULTRASON CELL (optional)*

The ultrasonic weeding cell is used to detect labels and transparent media. If you have transparent labels, this option is essential for the machine to work properly. In addition to detecting transparent labels, this cell also detects opaque labels.

## Technical focus n°11

### *LABEL RECORDING CELL (optional)*

The «label spotting» cell detects a label already present on the bottle in order to guide the application of a new label (a medal, a back label, etc.).

## Technical focus n°12

### *CAP CRIMPING WITH OR WITHOUT PRE-POSITIONING (SPOT MARKETING)*

Sparkling wines are often dressed in a cap (instead of the capsule for still wines). These caps are shaped to fit the neck of specific champagne bottles (or equivalents). The cap head allows the cap to be crimped to the shape of the neck.

The caps are sometimes printed with a coat of arms. A pre-positioning system can be fitted under the head to direct the coat of arms before crimping. The pre-positioning system rotates the bottle in order to locate a spot on the cap (contrast, UV, etc.) and thus angle the bottle before crimping.

## Technical focus n°13

### *ENCAPSULATING COLLAR STATION*

The caps on sparkling wine bottles are sometimes complemented by a surrounding label placed between the bottom of the cap and the glass. These labels are often called wrap-around labels. Because their shape is adapted to the neck, they require a specific station and process.

As with crimping, it is also possible to orient this label in relation to a coat of arms on the cap.

## Technical focus n°14

### *RECEPTION TABLE*

The reception table is installed at the machine exit to collect the dressed bottles. The 700 mm diameter table can receive up to 60 bottles.

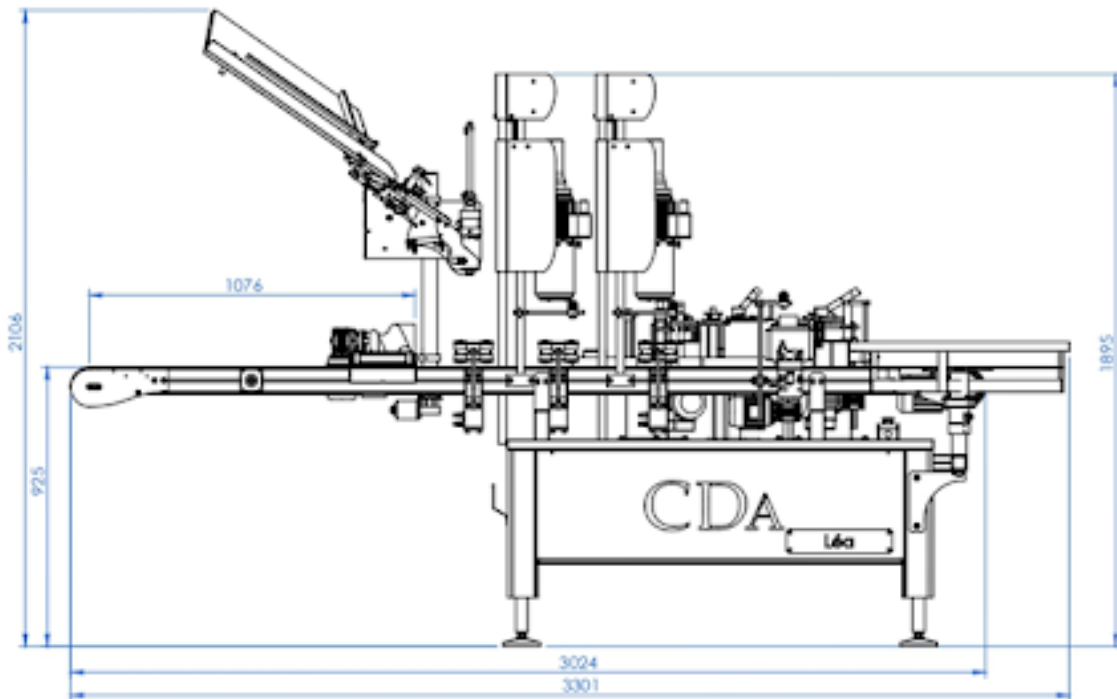

*Photos, prices and descriptions are indicative and non-contractual.*