

Cap System

Automatic monobloc for dispensing and crimping wine bottles.

Machine adapted to bottle sizes varying from 37.5 cl to 150 cl (Bordeaux to Burgundy) without additional tools.



The Cap System is an automatic machine equipped with :

- All stainless steel frame.
- A motorised conveyer (82.5mm wide).
- A multi-format automatic centering device.
- A multi-format selection screw.
- A capsule dispenser (height adjustment via touch screen).
- A touch screen to control and adjust (up to 50 height settings) the machine and a product counter.

Available options

- A mixed dispenser (suitable for capsules and caps).
- A crimper for caps.
- A crimper for caps.
- A rectangular table at the machine exit (capacity: up to 24 bottles depending on formats).
- A rotating cylindrical table at the machine exit (capacity: up to 60 bottles depending on formats).

This machine is upgradeable: the above options can be added at the customer's premises with the intervention of a technician.

Limits of the Cap System

- Bottles with a diameter greater than 115 mm

Technical characteristics

APPROXIMATE MASS (KG)	220 kg (depending option)
DIMENSIONS (WITH FRAME)	2566 mm in width 2099 mm in height 1034 mm in height
POWER CONSUMPTION	0.7kW (depending option)
SUPPLY VOLTAGE	380 V 5 wires (3P + T + N) Or 380 V 4 wires (3P+T) + outlet 220 v (To be specified on your order)
PNEUMATIC SUPPLY	6 bars Dry, non-lubricated air (Pipe Ø Int/Ext = 8/10 mm required)
CONTROL	by touchscreen
IDEAL OPERATING TEMPERATURE	from 50°F to 90°F (10°C to 30°C)

Please note that this machine requires an electrical and pneumatic power supply.

Technical focus n°1

AUTOMATIC MULTI-FORMAT CENTRING MACHINE

The automatic centring device allows products positioned on the conveyor to be centred. The product can thus undergo a given operation (dressing by a capsule dispenser, by a labelling station, etc.). The centring device is integral with the conveyor and adapts itself perfectly to the different formats of wine bottles (no adjustments or tooling changes).

Technical Focus n°2

TOUCHSCREEN

The colour touch screen allows easy adjustment of several parameters such as:

- Selection of stations and options
- Setting of time delays
- The speed of the clocking
- Daily product counter

Technical Focus n°3

MULTI-FORMAT SELECTION SCREW

The selection screw is used to create a regular pace between the products to be labelled. We say that it “paces” the products (saving considerable time).

Technical Focus n°4

CAPSULES DISPENSER

The capsule dispenser is a system for automatically depositing loose capsules on bottlenecks from capsule sticks. The height of the dispenser can be adjusted via the touchscreen.

The tray dimensions are 500 x 430 mm (maximum capacity 800 capsules). This dispenser can handle capsules with a diameter of 30 mm and a length in between 30 and 60 mm.

Capsules are ejected by a double blowgun, while a pneumatic cylinder deposits the capsule on the neck. The neck is centred and held automatically by a multi-format centring device.

Technical Focus n°5

CRIMPING SYSTEM (optional)

Whether you choose a roller crimper (8 rollers - 1400 rpm) or a thermal crimper, this option is used to automatically crimp caps that have previously been placed on bottles.

The choice between one or another of these crimping machines depends on the composition of your capsules: metal or plastic. CDA's crimping systems are equipped with automatic bottle centring and holding devices. The pace and height of crimping can be adjusted via the touchscreen.

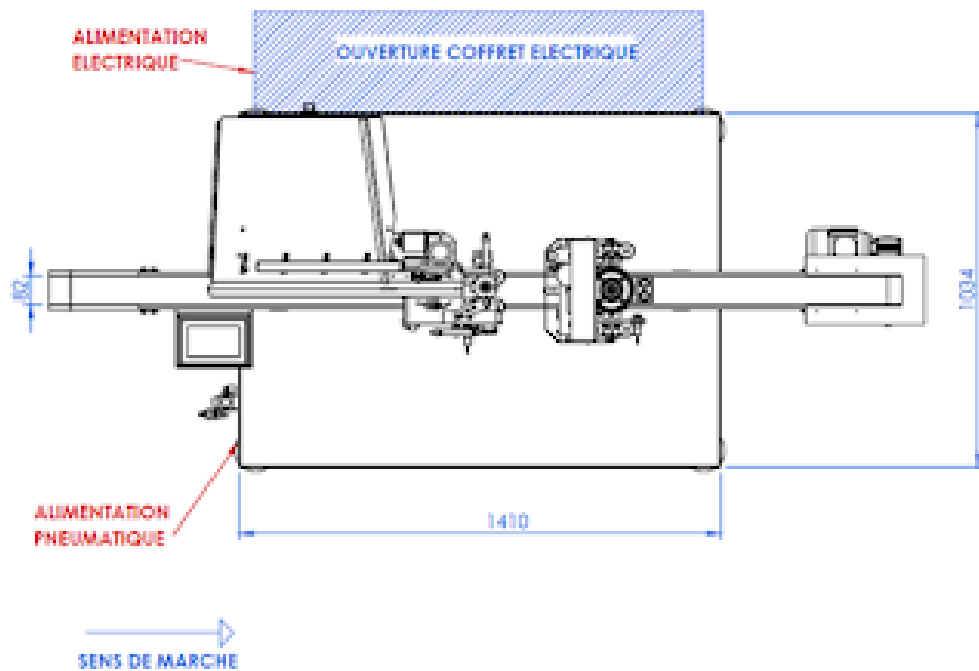
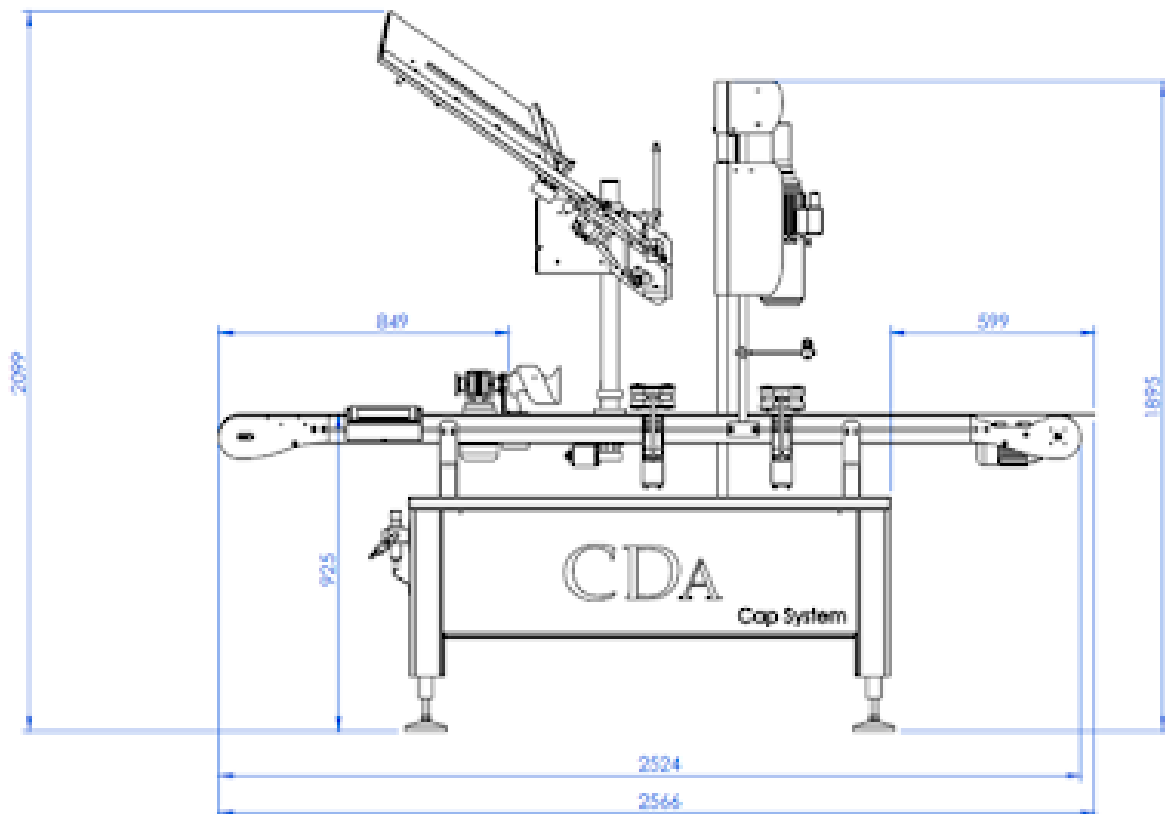

Attention à la hauteur sous plafond et au passage de porte

Photos, prices and descriptions are indicative and non-contractual.