

K-One

Semi-automatic filling machine

Semi-automatic filler - Dosing by peristaltic pump. Dosage between 0.5ml and 500ml.



The K-One is an semi- automatic filling machine equipped with :

- A touch screen allowing the adjustment and the piloting of the machine.
- A peristaltic pump.
- A pedal control.

Available options

- Tubes made of material adapted to the liquid(s) to be dosed.
- A connector.
- A dosing needle.
- A suction cannula.
- A non-return valve.

Limits of the K One

- Dosing volumes from 0.5ml to 500ml.
- Dosing of products with particles or high viscosity

Before placing an order, we can carry out tests free of charge to ensure the feasibility of your project. Please do not hesitate to contact us!

Technical characteristics K-One

APPROXIMATE MASS (LBS)	22 lbs - 10 kg with frame
DIMENSIONS (WITH FRAME)	310mm in width 290mm in height 410mm of depth
POWER CONSUMPTION	1 kW
SUPPLY VOLTAGE	208-250 V single phase
FREQUENCY	~ 50 Hz 16 A
CONTROL	by digital display
IDEAL OPERATING TEMPERATURE	from 50°F to 90°F (10°C to 30°C)

Please note that this machine requires an electrical power supply.

Technical Focus n°1

POWER SUPPLY

Electrical connection: 1 Cable 208-250 volts single phase – 10 Feet long - plug to be supplied according to your wall outlet.

Technical Focus n°2

PERISTALTIC PUMP

The peristaltic filling principle has many advantages. A perfect sterility, a guarantee against cross-contamination and no machine cleaning because the liquid is only in contact with the tube. The dosing is made possible by the crushing of tubes representing a dose. The peristaltic pump doses volumes from 0,5ml to 2L with a minimum accuracy of +/-0,5%.

Technical focus n°3

DOSING STAND

The K-one is delivered with a dosing stand to be placed on a table. The dosing stand consists of a height and depth adjustable needle holder and a height adjustable centering screw.

Technical focus n°4

FRAME (optional)

The dosing frame consists of a work table, a height and depth adjustable needle support, an adjustable centering vee and a shelf.

Technical Focus n°5

DIGITAL DISPLAY

The color touch screen allows you to easily adjust several parameters such as:

- Dose settings.
- A production counter.

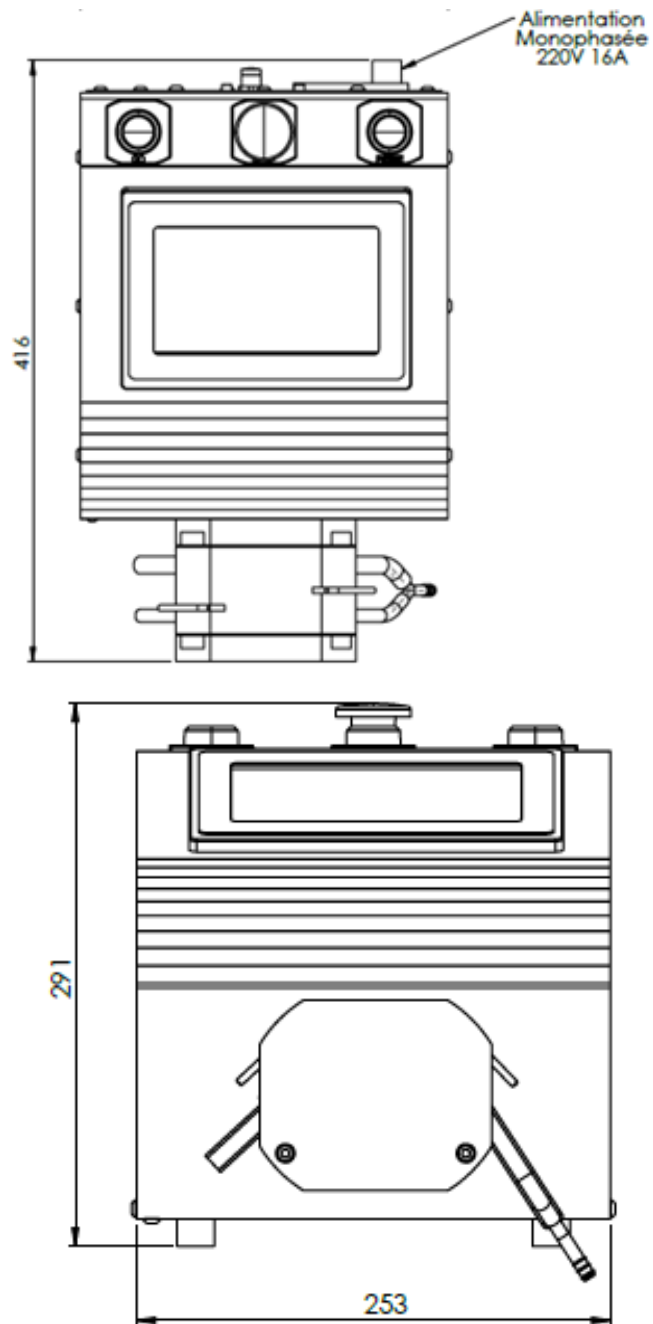

Pictures, production rates and technical descriptions for information.