

Solo Side

Automatic labelling machine for products with flat surfaces (rectangular, square, oval).

Automatic adhesive labeller - applies 1 label per product.
Suitable for products between 15 and 115 mm wide.

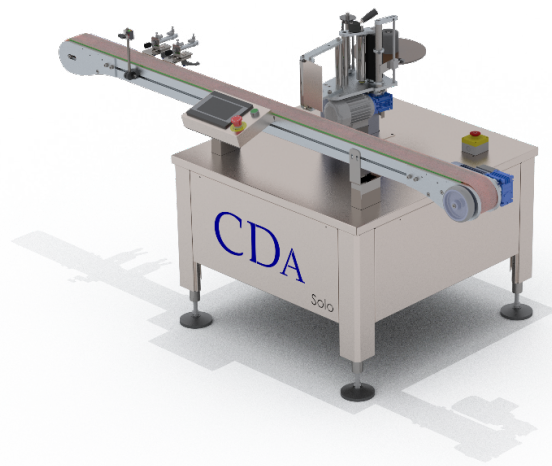

The Solo Side is an automatic labeller equipped with :

- An all stainless steel chassis.
- A motorised conveyor (82.6mm wide).
- An inclined label-applying station (SIDE POST) for labelling square, rectangular or oval products. The height of the station can accommodate reel heights from 10 mm to 155 mm (standard). The height at which labels are applied can be adjusted via the touch screen. The reel support plate can be disengaged.
- A 40 mm and 76 mm mandrel on which to place the label roll. The label roll is designed to be wound on the outside left.
- A product detection cell to trigger label application.
- A touch screen to control and adjust the machine, plus a product counter.

Options available

2

- A stainless steel profile conveyor with a choice of 82.6, 114.3 or 190.5 mm chain widths
- An aluminium profile conveyor with 190 mm chain width (82.6 mm as standard).
- A locking system to speed up product flow (by double jack, guided jack, etc.).
- Raised SIDE station(s). This option can accommodate reel heights of 230 or 285 mm (compared with 155 mm as standard).
- An automatic aligner to align and centre products.
- A stabiliser belt to drive the product at a constant speed.
- Side label flap system (side, top or double).
- Smoothing with pads.
- Rectangular product infeed table (for up to 24 products, depending on size).
- An independent rotary table for receiving products with a diameter of 700 or 1000 mm.
- A marker/coder for applying a use-by date, barcode, etc.
- An ultrasound cell for transparent labels.

This machine is upgradeable : some of the above options can be added on site with the intervention of a technician.

Limits of the Solo Side

- Products with flat surfaces higher than 390 mm and wider than 115 mm.
- Products with concave or convex surfaces to be labelled.
-

Technical specifications

APPROXIMATE WEIGHT IN KG	200 kg (depending on the option)
DIMENSIONS (WITH CHASSIS AND DEPENDING ON THE OPTION)	1280 mm wide 1700 mm high 2840 mm long
POWER CONSUMPTION	1 kW (depending on the option)
VOLTAGE/ELECTRICAL SUPPLY	1 220 volt cable - length 6 metres (To be specified when ordering)
PNEUMATIC POWER SUPPLY	6 bar constant - Dry, non-lubricated air (hose Ø Int/Ext = 8/10 mm)
CONTROL	by touch screen
IDEAL OPERATING TEMPERATURE	from 10°C to 30°C

Please note that this machine requires an electrical and pneumatic power supply.

Technical focus n°1

3

DIRECTION OF WINDING SIDE POST : OUTSIDE LEFT

The machine is designed to take rolls of labels with a left-hand outside winding direction. In addition, the dimensions of the rolls must be as follows:

- a: max core diameter = 76 mm (40 mm optional)
- b: maximum roll diameter = 325 mm
- c : max. coil height = 155 mm (285 mm optional)
- d : weatherstripping = 3-5 mm

The characteristics (material, grammage, adhesive, dimensions, etc.) of the label must be consistent with the requirements and the type of bottle.

Note : Label reels should be stored in a dry place between 15°C and 18°C.

Don not hesitate to contact your sales representative or your printer, case-by-case solutions can be found.

Technical focus n°2

TOUCH SCREEN

The colour touch screen makes it easy to set a number of parameters, such as :

- Selecting stations and options.
- Timer settings (label output, spacing).
- Keying speed
- Day counter.

Technical focus n°3

MOTORISED CONVEYOR

The conveyor designed by CDA is made of an anodised aluminium profile, which holds a 82.6 mm wide acetal pallet chain (the width of this chain can be 190 mm upon request). Width-adjustable stainless steel side guides (diameter of 12 mm) guide the passage of the products. The conveyor/motor unit is mounted on a stainless steel frame into which the electrical box is integrated.

Technical focus n°4

SIDE POST

The labelling station for flat products is driven by asynchronous motors and frequency inverters. This station applies the labels «on the fly», which are then smoothed by a brush or roller (standard maximum reel height 155 mm).

The CDA labelling station is mounted on an electric column, so the height at which the label is applied can be adjusted via the touch screen. No manual adjustments or tools are required to set the label height.

The SIDE station's reel support tray can be disengaged to accommodate a roll of labels with a diameter of 325 mm (standard).

Technical focus n°5

AUTOMATIC ALIGNOR (optional)

The automatic aligner is used to align oval or rectangular products. The aligner consists of a double chain driven by asynchronous motors and controlled by variable speed drives. This device is synchronised with the conveyor speed. The aligner is adjusted to the width of the product using a handwheel (position indicator).

4

Technical focus n°6

STABILISER BELT (optional)

The stabiliser belt is a belt (driven by an asynchronous motor and controlled by a variable speed drive) synchronised with the speed of the conveyor. It is mounted on an electric column and its height can be adjusted via the touch screen. The stabiliser belt stabilises the product by pressing down on it from above, and drives it at a constant speed as the front and/or back labels are applied.

Technical focus n°7

ULTRASON CELL (optional)

The ultrasonic weeding cell is used to detect labels and transparent media. If you have transparent labels, this option is mandatory for the machine to work properly. In addition to detecting transparent labels, this cell can also detect opaque labels.

Technical focus n°8

LABEL SPOTTING CELL (optional)

The «label locating» cell detects a label already present on the bottle in order to guide the application of a new label (a medal, a back label, etc.).

Focus technique n°9

RECTANGULAR RECEPTION TABLE

The rectangular reception table is installed at the machine exit to collect the labelled bottles. The 580 x 460mm table can handle up to 45 containers (for a Ø60mm diameter container).

Technical Drawing

5

