

VST

Automatic dispensing and pressing of T-top corks



The VST is an automatic dispensing and pressing machine equipped with :

- All-stainless steel frame with 1500 mm motorized conveyor, 82.5 mm wide acetal pallet chain.
- Control panel with programmable screwing time and other timers.
- A product detection and stopping device under the capping head, with pneumatic symmetrical centering device equipped with various centering screws.
- Machine complies with CE standards.

Available options

- An automatic product feeding system (cylindrical or rectangular feeding table, transfer plate, etc.)
- An automatic product infeed system at the machine entrance (independent cylindrical feeding table, rectangular feeding table, transfer plate, etc.)
- An automatic product accumulation system at the machine exit (independent cylindrical accumulation table, rectangular, a transfer plate...)

Before placing an order, we can carry out tests free of charge to ensure the feasibility of your project. Do not hesitate to contact us!

Technical characteristics VST

APPROXIMATE MASS (LBS)	990 lbs - 450 kg (depending option)
DIMENSIONS (WITH FRAME)	1006 mm en largeur 2702 mm en hauteur 2176 mm de longueur
POWER CONSUMPTION	1 kW
POWER SUPPLY	220 V mono
FREQUENCY	~ 50 Hz 16 A
CONTROL	by digital display
IDEAL OPERATING TEMPERATURE	from 50°F to 90°F (10°C to 30°C)

Please note that this machine requires an electrical and pneumatic power supply

Technical Focus n°1

PNEUMATIC / ELECTRICAL CONNECTION

Pneumatic connection: 1 air connection on pressure gauge - Under 6 bars constant (Hose to be provided \emptyset Int/Ext = 8/10 mm).

Electrical connection: 1 Cable 208-250 volts single phase - length 18 feet - Plug to be supplied according to your wall outlet.

Technical Focus n°2

DIGITAL DISPLAY

The color touch screen allows easy adjustment of several parameters such as:

- Timer settings
- Daily product counter
- Selection of screwdriver components

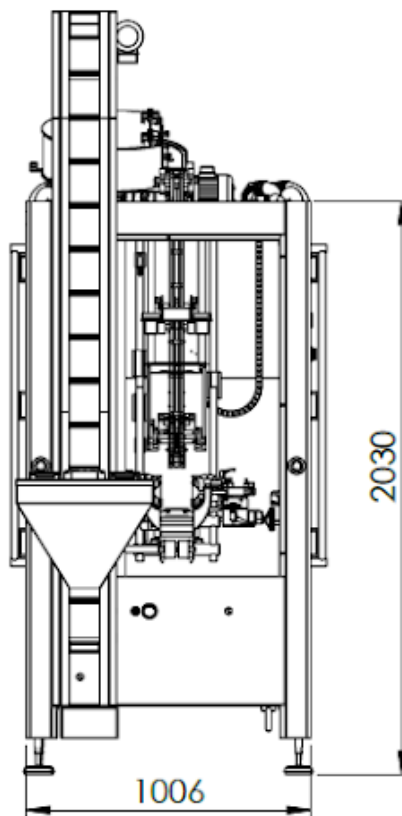
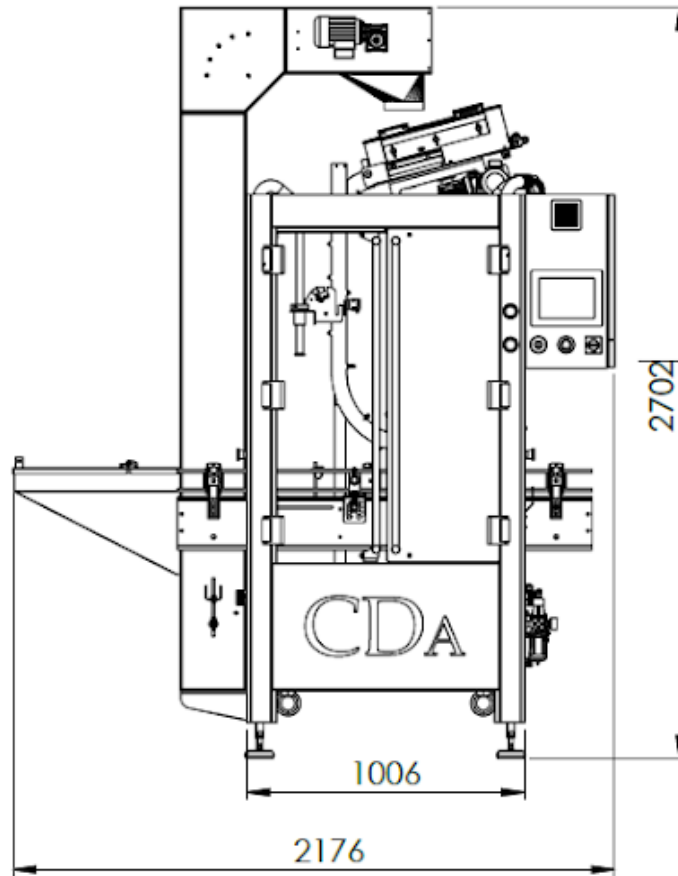

Photos, prices and descriptions are indicative and non-contractual.